

MODEL: S1201W01

Thread	Max Tightening torques	
M6	8.8N.m	90Kgf.cm
M8	21.4N.m	220Kgf.cm
M10	44N.m	450Kgf.cm
remark: 1N.m=10.197Kgf.cm		

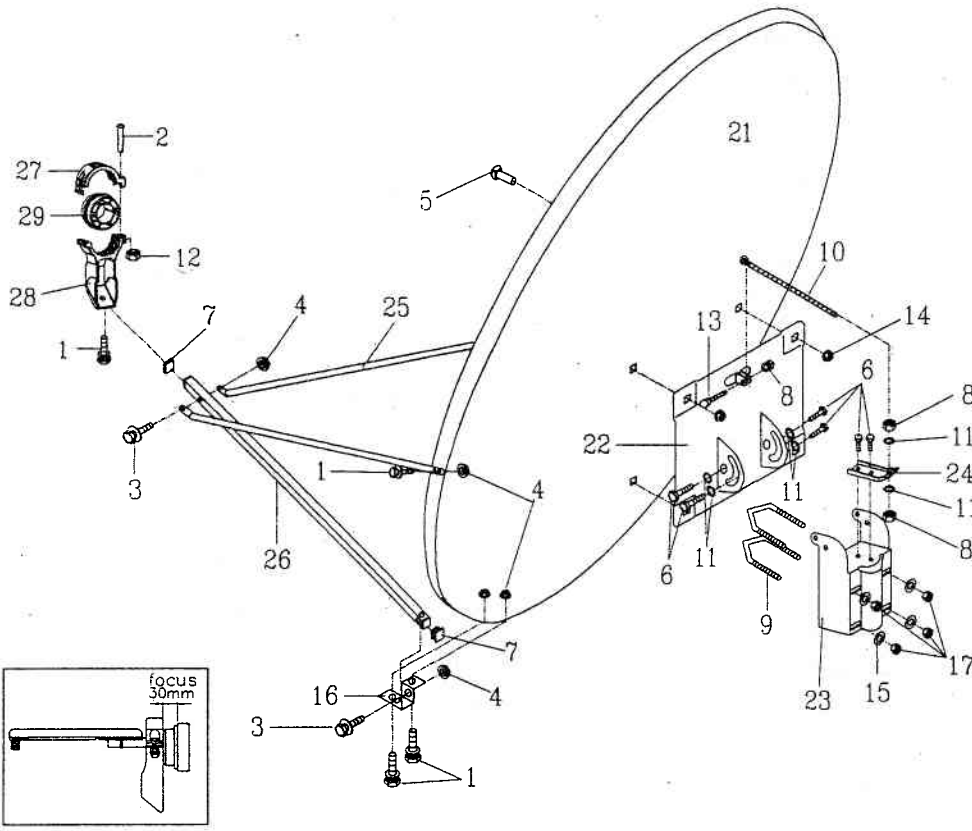

29		23mm LNB Clamp	1
28		40mm LNB Clamp Holder	1
27		40mm LNB Clamp	1
26		LNB Arm	1
25		Feedhorn(LNB) Supporting Rods	2
24		Elevation Plate	1
23		Pole Adapter	1
22		Reflector Bracket	1
21		Reflector	1
17		M8 hex nut	4
16		20*26 fixing clamp	1
15		8 washer	4
14		M8 flange nut	4
13		M10*25 hex-head cap screw	1
12		M4 hex nut	1
11		10 washer	6
10		M10*260 screw	1
9		M8 square U bolt	2
8		M10 hex nut	3
7		cover	2
6		M10*20 hex-head cap screw	6
5		M8*20 round-head screw	4
4		M6 flange nut	6
3		M6*35 hex-head cap screw w/w	2
2		M4*20 Round-head cross screw	1
1		M6*12 hex-head cap screw w/w/sw	5
NO.	ITEM	DESCRIPTION	Q'TY

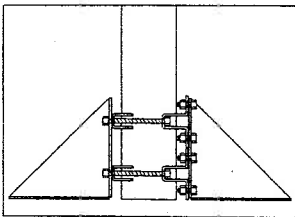
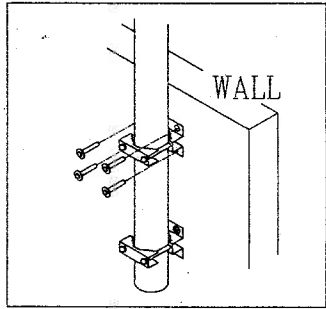
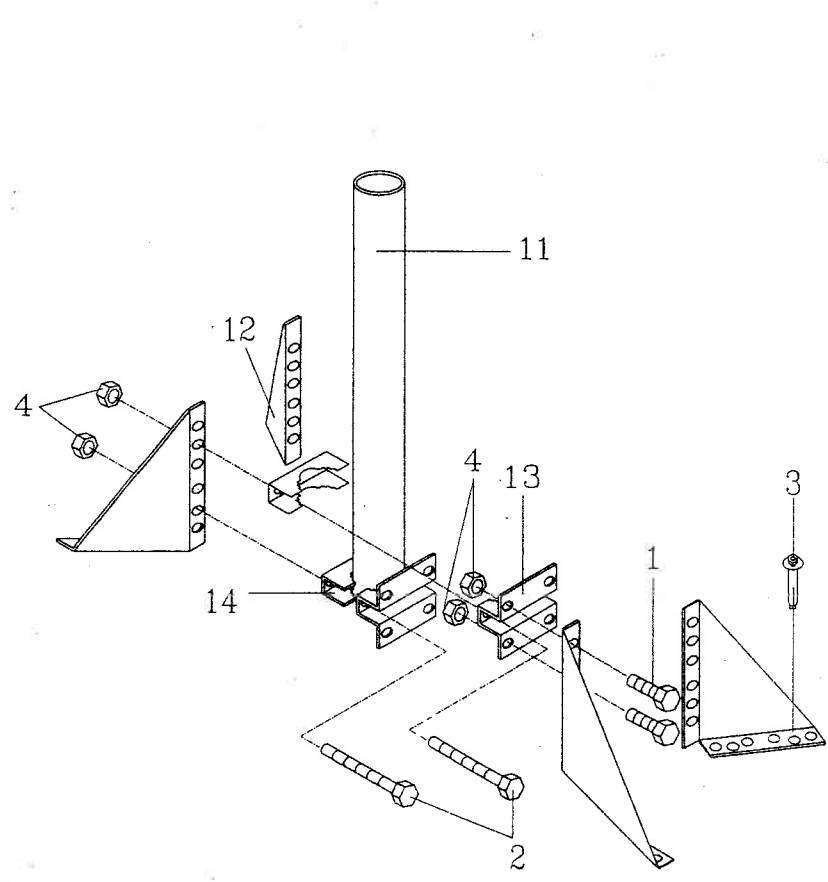

14		B/Mounting Bracket	2
13		F/Mounting Bracket	2
12		Mounting plate	4
11		Pole	1
4		M10 hex nut	12
3		1/4*1-1/2 Anchor bolt	8
2		M10*80 hex-head cap screw	4
1		M10*20 hex-head cap screw	8
NO.	ITEM	DESCRIPTION	Q'TY